

SILVERPAK 17T

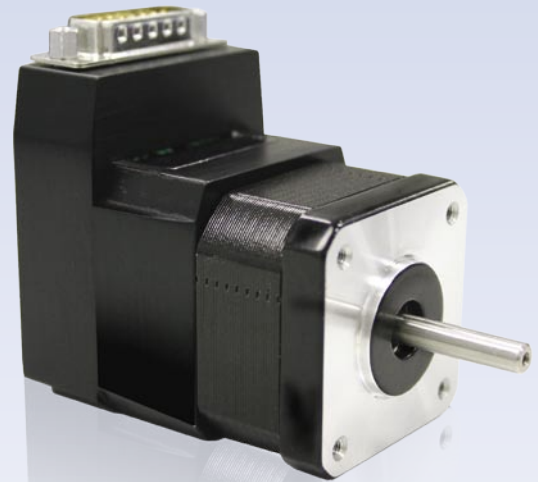

FEATURES

- Integrated Bipolar 1.8° Step Motor with Driver/Controller
- NEMA Size 17 Frame
- Holding Torque of up to 85 oz-in
- Input voltage of +7 to 28 VDC
- Output currents of 0.1 to 1.5 Amps Peak
- Step resolution of full step, 2x, 4x, 8x, and 16x microstepping
- Maximum speed of 250 kHz
- Up to 16 MHz of Step Clock Frequency
- Two digital limit switches, left and right
- One general purpose input (digital or analog)
- One open collector output capable of outputting 100mA
- Low power dissipation – no heat sink required
- Stand alone operation with no connection to PC
- Incorporated with TMCL Programming Language
- Up to 16 kBytes of Memory (2048 TMCL commands)
- Programmable settings for acceleration and velocity profiles
- Control commands such as Jump and Subroutines available
- Calculation and compare commands implemented
- StallGuard™ feature available
 - capable of detecting a stall without encoder
- RS485 communication
- 3 stack lengths available

SPECIFICATIONS

- **INPUT VOLTAGE:**
+7 to 28 VDC
- **DRIVE CURRENT(PER PHASE):**
0.1 to 1.5 Amps Peak
- **I/O's:**
2 I/O's, Switch Closure to Ground, Opto Phototransistor
- **STEP FREQUENCY (MAX):**
250 kHz
- **STEPS PER REVOLUTION (1.8° MOTOR):**
200, 400, 800, 1600
- **MICROSTEP RESOLUTIONS (1.8° MOTOR):**
Full, 2x, 4x, 8x, 16x

DIMENSIONS (inches)

A. Overall Body Length

TO-4118S: 2.76" (70.1 mm)

TO-4118M: 2.99" (75.9 mm)

TO-4118L: 3.31" (84.1 mm)

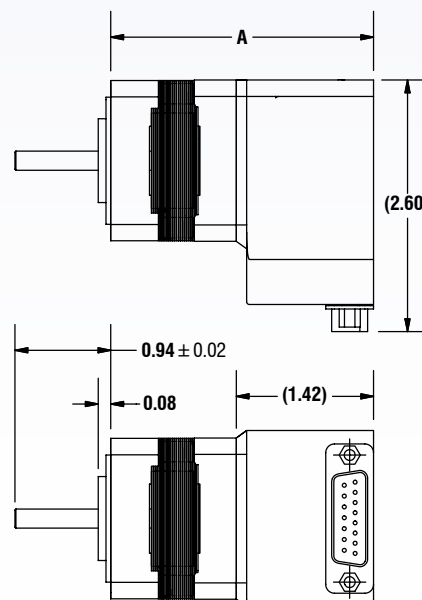
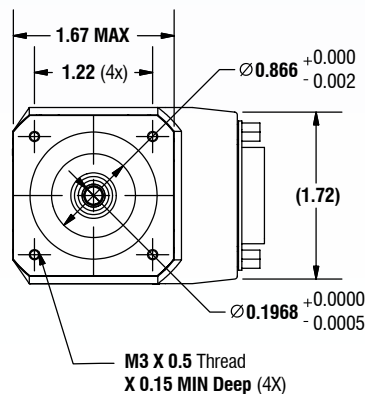

TORQUE CURVES

TO-4118S-09 24vDC, 1.26 Amps Peak, SilverPakT, 1/2 Stepping

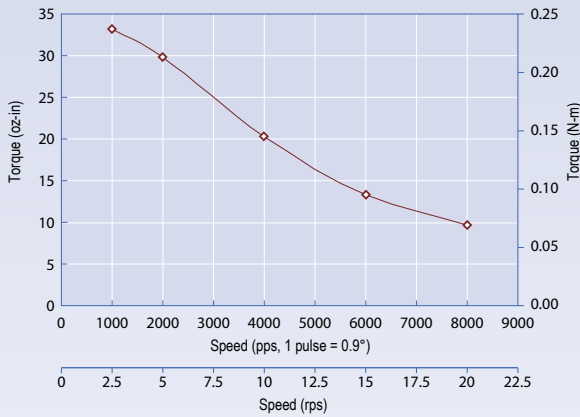

TO-4118M-06P 24vDC, 1.5 Amps Peak, SilverPak T, 1/2 Stepping

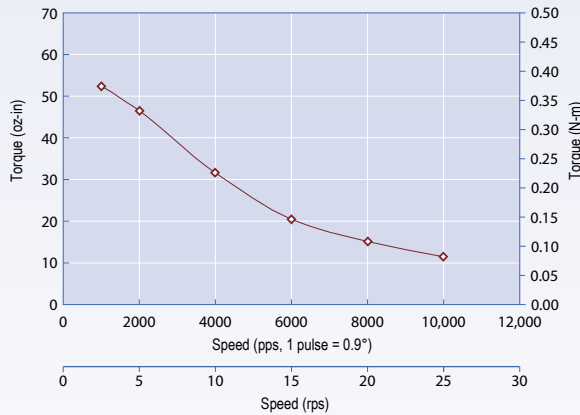

TO-4118L-07S 24vDC, 1.05 Amps Peak, SilverPakT, 1/2 Stepping

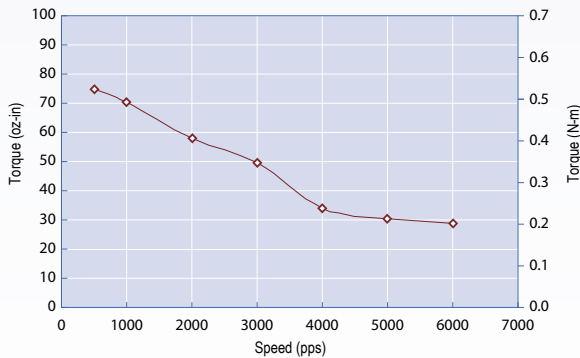

MOTOR SPECIFICATIONS

Model TO-4118S-09

Holding Torque oz-in (N-m)	45.00 (0.32)
Rotor Inertia oz-in ² (kg-cm ²)	0.18 (0.03)
Weight (Motor + Driver) lbs (gm)	0.55 (0.25)

Model TO-4118M-06P

Holding Torque oz-in (N-m)	63.00 (0.45)
Rotor Inertia oz-in ² (kg-cm ²)	0.28 (0.05)
Weight (Motor + Driver) lbs (gm)	0.75 (0.34)

Model TO-4118L-07S

Holding Torque oz-in (N-m)	85.00 (0.60)
Rotor Inertia oz-in ² (kg-cm ²)	0.37 (0.07)
Weight (Motor + Driver) lbs (gm)	0.85 (0.39)

RECOMMENDED ACCESSORY

USB485 Converter Card



For more details, see page 85.